

# Design Principles for Wood Burning Cook Stoves



**Aprovecho Research Center  
Shell Foundation  
Partnership for Clean Indoor Air**

**The Partnership for Clean Indoor Air** was launched by the U.S. Environmental Protection Agency (EPA) and other leading partners at the World Summit for Sustainable Development in Johannesburg in September 2002 to improve health, livelihood, and quality of life by reducing exposure to indoor air pollution, primarily among women and children, from household energy use. Over 80 organizations are working together to increase the use of clean, reliable, affordable, efficient, and safe home cooking and heating practices that reduce people's exposure to indoor air pollution in developing countries. For more information, or to join the Partnership, visit [www.PCIAonline.org](http://www.PCIAonline.org).

This document was developed by Aprovecho Research Center under a grant from the Shell Foundation to provide technical support to household energy and health projects to ensure that their designs represent technical best practice. The principle authors of this booklet include: Dr. Mark Bryden, Dean Still, Peter Scott, Geoff Hoffa, Damon Ogle, Rob Balis, and Ken Goyer.

Indoor air pollution causes significant health problems for the 2 billion people worldwide that rely on traditional biomass fuels for their cooking and heating needs. Over the last 30 years, awareness of the environmental and social costs of using traditional fuels and stoves and knowledge about how to reduce emissions from these stoves has grown. Yet the improved stoves currently available to poorer customers do not always represent best practice or an understanding of design based on modern engineering. The knowledge required to design cleaner burning stoves exists in centers of excellence in several locations around the world. Providing this information to those involved in promoting improved stoves is a necessary first step to reducing indoor air pollution exposure for stove users.

Aprovecho is a center for research, experimentation and education on alternative technologies that are ecologically sustainable and culturally responsive. The Advanced Studies in Appropriate Technology laboratory at Aprovecho works to develop energy efficient, nonpolluting, renewable technologies that reflect current research but which are designed to be made in most any country. The center is located on a beautiful 40-acre land trust near Eugene, Oregon. For more information on Aprovecho, visit [www.Aprovecho.net](http://www.Aprovecho.net).

**Illustrations:** Mike Van, Jayme Vineyard, and Ethan Hughes

# Design Principles for Wood Burning Cook Stoves

Dr. Mark Bryden, Dean Still, Peter Scott, Geoff Hoffa, Damon Ogle, Rob Bailis, Ken Goyer

## Table of Contents

---

**Introduction** .....5-6

**Chapter 1 - Stove Theory** .....7-11

**Chapter 2 - Ten Design Principles** .....12-16

**Chapter 3 - Designing Stoves with Baldwin and Winiarski** .....17-25

**Chapter 4 - Options For Combustion Chambers** .....26-29

**Chapter 5 - In Field Water Boiling Test** .....30-35

**Appendix - Glossary of Terms** .....37-38



# Introduction

## Proven Strategies

Indoor air pollution causes significant health problems for the 2 billion people worldwide who rely on biomass fuels for their cooking and heating needs. Over the last 30 years awareness of the environmental and social costs of using traditional fuels and stoves has grown. At the same time, studies of the problem have resulted in proven strategies to reduce both fuel use and harmful emissions. Unfortunately, the local stoves currently available do not always represent the best designs that modern engineering can offer. This booklet is an attempt to address the problem by summarizing some of the advances in stove theory and design. Understanding these concepts would be useful to administrators of stove projects, policy makers, field workers, and cooks alike.

Although open fires are often used wastefully, carefully operated open fires can be fuel efficient and clean burning when tested in the lab. In many situations, cooks are not overly concerned with fuel use, and studies have shown that when fuel is plentiful three-stone fires can use an excessive amount of wood to cook a small amount of food. But in other places where fuel is scarce, open fires can be carefully controlled so that fuel efficiency rivals many first generation improved cook stoves.

How an operator controls the open fire makes the difference, as in the use of other tools. In the seventies and early eighties, open fires were generally characterized as being basically inefficient. But it was by analyzing the open fire that researchers were able to develop truly improved stoves. Dr. Grant Ballard-Tremeer and Dr. Kirk Smith were foremost among those who found that the three stone fire could be both more fuel efficient and cleaner burning than some “improved” cook stoves.

Respecting that indigenous technologies are evolved from countless years of experimentation

and have great worth changes the perspective of scientists who are trying to address the causes of human suffering. Watching how experts operated the open fire has taught engineers how to design even better stoves. Modern cook stoves are designed to clean up combustion first. Then the hot gases can be forced to contact the pot increasing efficiency without increasing harmful emissions.

Fires can be clean burning when expert cooks push the sticks of wood into the fire as they burn, metering the fuel. The open fire can be a hot fire useful when food or drink needs to be prepared quickly. The energy goes into the pot, not into the cold body of a stove. The open fire can burn wood without making a lot

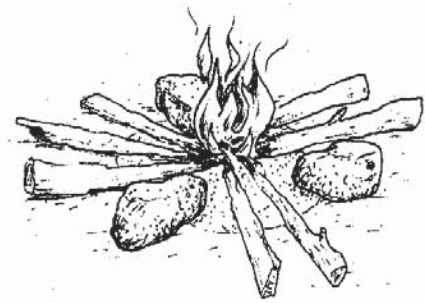

**Figure 1** - Traditional Wood Fire

fires burn smoke as it is released from the wood. Unfortunately however, many fires used for cooking are built emphasizing simplicity of use and are wasteful and polluting.

Modern stoves score higher when tested than even the most carefully operated fire in the laboratory. Good stoves can offer many advantages. Stoves do much more than save wood and reduce smoke. How the stove cooks food is usually most important to the users!

Improved stoves can make cooking with fire easier, safer, faster, and can add to the beauty of the kitchen. A good stove is quicker to start, needs little tending, and can meet the specific needs of a cook. The successful design is appreciated as an addition to the quality of life and usually these concerns far outweigh scores on a test.



## Decades of Investigation

Many investigators have contributed to a modern understanding of the thermodynamics of cooking stoves. The scientific study of wood burning stoves has reached the point where a great deal of consensus now exists about how stoves function. Dr. Larry Winiarski has studied combustion and wood burning cooking stoves for more than thirty years. He has helped organizations build thousands of stoves in countries around the world. Dr. Winiarski is the Technical Director of the Aprovecho Research Center, where stoves have been a major topic of study since 1976. The team at Eindhoven University, led by Dr. Krishna Prasad and including Dr. Peter Verhaart and Dr. Piet Visser, experimented with wood stoves for more than a decade and wrote pivotal books on the subject. Dr. Sam Baldwin summarized years of experience in West Africa and in the lab in his comprehensive book *Biomass Cookstoves: Engineering Design, Development and Dissemination* (1987).

Chapter One, *Stove Theory*, outlines the work of these leading researchers and offers strategies that a stove designer can use to improve a stove.

Chapter Two, *Ten Design Principles*, details the synthesis of design created by Dr. Larry Winiarski.

Chapters Three and Four, *Designing Stoves with Baldwin and Winiarski*, and *Options for Combustion Chambers* contain technical information to support the designer in charge of developing a stove project.

And lastly, chapter Five, *In Field Water Boiling Test*, provides designers with an in field method for measuring the performance of stove prototypes as they are developed. The test does not require a computer or complicated calculations for data analysis.

## Respect for local knowledge

We hope that the following design principles add to a project, highlighting the respect and inclusion of local knowledge. A sensitivity and appreciation of local knowledge supports a two-way information exchange, learning from the expertise of local people and their technology while sharing knowledge.

Hopefully, sharing design principles is more inclusive than promoting a static stove design. The literature frequently points out that local inventiveness has a place in every part of a stove project. Without information from the community that will be using the stove, a project is starved for the input needed for success.

All members of a design committee including cooks, craftspeople, administrators, promoters and technical advisors can easily learn stove design principles. The inventiveness and practical experience of the whole team is essential to create a product that suits local needs and ‘tastes’.

The empowerment found in the design process can serve as motivation for locals to become trainers, promoters, designers, and builders. Technical staff frequently find valuable input about design, manufacture, and promotion from the users and learn just as much as they teach. Perhaps the conclusion that stove projects are more likely to succeed when all concerned help to create the design parallels the hope that better representation will create solutions to larger problems.

## Chapter 1

# Stove Theory

Even an open fire is often 90% efficient at the work of turning wood into energy. But only a small proportion, from 10% to 40%, of the released energy makes it into the pot. Improving combustion efficiency does not appreciably help the stove to use less fuel. On the other hand, improving heat transfer efficiency to the pot makes a large difference.

Improving the combustion efficiency is necessary to reduce smoke and harmful emissions that damage health. Improving heat transfer efficiency can significantly reduce fuel use. Fire is naturally good at its job, but pots are not as good at capturing heat because they are inefficient heat exchangers. In order to reduce emissions and fuel use, *the stove designer's job is to first clean up the fire and then force as much energy into the pot or griddle as possible.* Both of these functions can be accomplished in a well engineered cooking stove.

It is always best practice to add a chimney to any wood burning cooking or heating stove. Additionally, it is preferable to use a cleaner burning stove to protect air quality in and outside of the house. Chimneys that take smoke and other emissions out of the living space protect the family by reducing exposure to pollutants and health risks. Even cleaner burning stoves without a chimney can create unhealthy levels of indoor air pollution.

Unvented stoves should be used outdoors or in open areas. When chimneys are not affordable or practical using a hood over the fire, or opening windows, or making vents in the roof under the eaves are all ways to decrease the levels of harmful pollution. The use of a cleaner burning stove can also be helpful in this regard but, if possible, all wood burning stoves should always be fitted with a functional chimney!

How can we design a stove that improves upon the open fire? First, let's list the advantages of the three-stone fire when compared to some stoves:

- ▶ No energy is absorbed into the mass of a stove body. High-mass stoves can absorb energy that could have gone into the pot. The three stone fire can boil water fairly quickly.
- ▶ Fire hits the bottom and sometimes the sides of the pot, exposing a lot of the pot to the hot gases.
- ▶ Sticks can be fed in at the appropriate rate as the tips burn, assisting complete combustion.
- ▶ A hot open fire can burn relatively cleanly. Every stove suffers because it has some mass that absorbs heat. But an improved stove can still achieve better combustion and fuel efficiency than an open fire.

## How to improve combustion

(make less harmful pollution compared to an open fire)

- ▶ Make sure there is good draft into the fire.
- ▶ Insulate around the fire to help it burn hotter. A hotter fire burns up more of the combustible gases and produces less smoke.
- ▶ Avoid using heavy, cold materials like earth and sand around the combustion chamber.
- ▶ Lift the burning sticks up off the ground so that air can scrape under the sticks and through the charcoal.
- ▶ Placing an insulated short chimney above the fire helps to increase draft and gives smoke, air, and fire a place to combine, reducing emissions. This is a popular strategy used in many stoves such as the Z stove, the Vesto, the Wood Gas Camp Stove, the Rocket stove, the Tso-Tso stove, etc. The Eindhoven group used a chimney above the fire in their cleanest burning downdraft stove. Micuta built stoves incorporating this idea as well (*Modern Stoves for All*, 1981). Winiarski developed the concept in the early 1980s creating a stove that cleaned up

combustion and improved heat transfer efficiency (*Capturing Heat One*, 1996).

- ▶ Meter the sticks of wood into the combustion chamber to make a hot, fierce, jumpy looking fire that does not make much charcoal. This type of fire will make less dangerous emissions, chimney clogging soot, and creosote. Heat only the burning part of the wood. Do not encourage the non-burning wood to make smoke.
- ▶ Limit the cold air entering the fire by using as small an opening as possible. Small openings into the fire also force the cook to use less wood, which can be burnt more efficiently.
- ▶ A certain amount of excess air is necessary for complete combustion. Preheating the air helps to maintain clean combustion.

## How to improve fuel efficiency

(get more heat into the pot)

- ▶ Increase the temperature of the gas/flame contacting the pot, having the hot air scrape against both the bottom and sides of the pot in a narrow channel, using a pot skirt.
- ▶ Increase the speed of the hot flue gases that scrape against the pot. The fast gases punch through a boundary layer of still air that keeps slower moving gases from scraping against the surface of the pot (or griddle.) Air is a poor heat transfer medium. It takes a lot of hot air to bring heat to the pot.
- ▶ Use metal rather than clay pots because metal conducts heat better than clay.
- ▶ The size of the fire determines the size of the

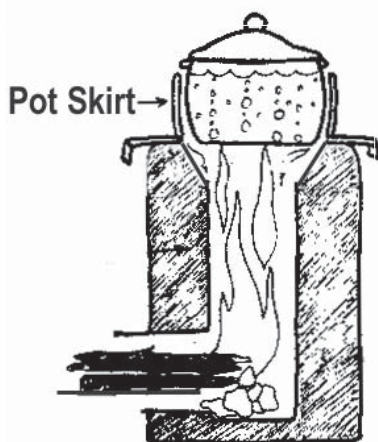

**Figure 2** - Appropriate Use of Pot Skirt

channel gap in the pot skirt and the maximum efficiency of heat transfer. *Smaller fires that* can still please cooks but are not too big will be considerably more fuel efficient.

- ▶ Use wide pots with large diameters. Using a wide pot creates more surface area to increase the transfer of heat. Make sure that the top of the stove slopes up toward the outer perimeter of the pot, as shown in Figure 2.

Sam Baldwin's *Biomass Stoves: Engineering Design, Development, and Dissemination* (1987) is a very good summary of how to make improved stoves. It is highly recommended. Dr. Baldwin figured out how the channel size between pot and skirt, firepower and efficiency are related. Here are a few examples using a family sized pot:

- 1.) A 1.7 kW fire with a channel gap of 6 mm that forces hot flue gases to scrape against the pot for 15 cm will be about 47% efficient.
- 2.) 4 kW fire with a channel gap of 10 mm that forces heat to scrape against the pot for 15 cm will be about 35% efficient.
- 3.) A 6 kW fire with a channel gap of 12 mm that forces heat to scrape against the pot for 15 cm will be about 30% efficient.
- 4.) A 8 kW fire with a channel gap of 14 mm that forces heat to scrape against the pot for 15 cm will be about 26% efficient.

As an approximate, general rule of thumb, Baldwin recommends that a family sized stove that burns less than one kg of wood per hour can use a channel gap between pot skirt and pot of 11 mm. If the stove burns 1.5 kgs per hour the gap needs to be 13 mm. If 2 kilos of wood are burnt per hour then the gap should be 15mm. Please refer to *Biomass Stoves* for complete information.

In wood burning stoves a lot of the heat is transferred to the pot or griddle by convection. The amount of wood burnt per hour and channel gap are related. If the pot skirt gap is made too narrow, there is insufficient draft and smoke backs up into the room.



Increase heat transfer to the pot by keeping the temperature of the hot flue gases as high as possible. Insulate everywhere the heat goes except to the pot or griddle. If there is enough surface area in the stove for the hot flue gases to scrape against, the flue gases will be much colder by the time they exit out of the chimney. If exit temperatures in the chimney are above 200° C, add more surface area to make use of the heat. Secondary pots or griddles placed near the chimney may never boil water but they can help preheat cooking water and warm food and dishwashing or bathing water.

Using a pot skirt also forces more heat into the pot by forcing the hot flue gases to continue scraping against the pot all along its sides in addition to its bottom.

A haybox makes even more efficient use of captured heat. Placing the boiling pot of food in an airtight box filled with insulation holds the heat in the pot, and food cooks without using added fuel (See Figure 4).

Once the food has boiled, the fire can be extinguished. Placing the pot of food in an insulated cooking box most effectively uses the heat to accomplish the task of cooking. The haybox does all simmering without using extra fuel. This technique saves tremendous amounts of wood. And using a retained heat cooker saves time for the cook who lets the haybox do the simmering!

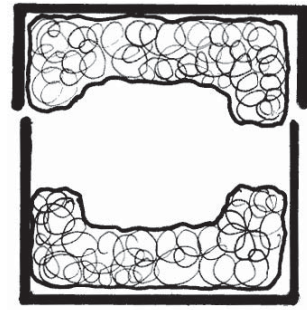

**Figure 3** - Top Down View of Haybox

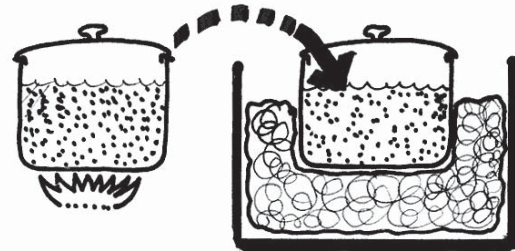

**Figure 4** - Placing Boiling Pot in the Insulation

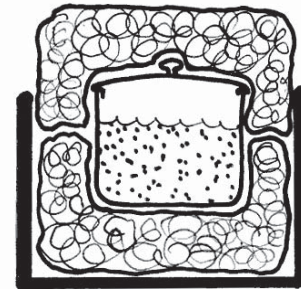

**Figure 5** - Putting Insulating Lid on the Haybox



**Figure 6** - Food Continues to Cook Inside the Insulated Haybox

## Common Misconceptions

### 1. Retained energy in the stove body helps to cook food.

**FALSE**

Experiments by Baldwin have shown that retained energy is mostly lost. Leftover charcoal can heat food after the fire has been extinguished but retained energy in the stove body is usually too cold to effectively heat pots.

Note that retained energy in a stove can be advantageous if the stove is used for space heating.

### 2. Keeping energy in the stove by decreasing the draft will help to cook food. Lowering the exit temperatures in the chimney means that the cook stove is operating well.

**FALSE**

As stated, slowing down the draft hurts both combustion and heat transfer. Hot flue gases need increased velocity to achieve good heat transfer.

### 3. Using a damper in the chimney helps to make a stove work better.

**FALSE**

Again, slowing down the draft in a cooking stove is usually detrimental. Dampers should not be used in a well designed cooking stove.

### 4. Packed earth or stone acts like insulation.

**FALSE**

Dense materials absorb energy rather quickly while insulation slows the passage of heat. Insulation is made of pockets of air separated by a light weight less conductive material.

Insulation is light and airy. Heavy materials are better examples of thermal mass. Insulation helps a stove to boil water quickly; thermal mass robs energy from the pot which makes water take longer to boil.

### 5. Anything is better than an open fire.

**FALSE**

An open fire can boil water faster than many heavy stoves. The three stone fire can be clean burning and relatively fuel efficient. While the open fire can be wasteful when used carelessly, the early estimates that any stove was better has been replaced with a new respect for this ancient technology. Engineers have learned how to design improved cooking stoves by learning what is great about the three stone fire.

## Testing is essential

Dr. Baldwin includes a remarkably thorough chapter on stove testing in *Biomass Stoves*. He points out that the testing of prototypes is necessary while the stove is being developed. Testing stoves also helps determine if the model is marketable, whether production costs are as low as possible, and if improvements are needed. Testing should happen during the entire life of a stove project.

Baldwin includes tests to determine whether consumers are happy with the product, if firewood is being saved, and how lifestyle issues are affected. Without continual testing, a stove project operates in the dark; it lacks essential technological, sociological, and business information. Reading the stove testing chapter in *Biomass Cookstoves* is highly recommended.

Careful testing of stoves has resulted in a more accurate understanding of how to make better stoves. Without experimentation and testing, the development of a stove is based on conjecture. Careful investigation can quickly separate truth from opinion. Testing has a twofold function: to identify problems and to point out solutions. It is an essential ingredient for progress. A simple water boiling test is included in Chapter 5 on page 30.

## Make stoves safe!

**Preventing burns is quite possibly one of the most important functions of an improved stove.**

Burns are quite common in homes using fire and can be fatal or horribly disfiguring. To protect the family the stove body should not be hot enough to cause harm. Stoves and pots should be stable. Surround the fire with the stove body so that children cannot be burnt. Injuries from fire are a major problem that stoves can remedy.

Chimneys or smoke hoods can be used to get smoke out of the kitchen. According to recent estimates by the World Health Organization, up to 1.6 million women and children die every year from breathing polluted air in their houses. Pneumonia and other respiratory diseases in children are caused by breathing smoke. Unvented stoves can be used outdoors, under a roof, or at least near a large window. Operational chimneys and airtight stoves can remove essentially all pollution from the indoor environment. Chimneys are used in industrialized countries and are required for protecting families from dangerous emissions. Shouldn't people in poorer countries be provided with the same protection?

## Chapter 2

# Ten Design Principles

Dr. Larry Winiarski's design principles have been used by many organizations to create successful stoves. The HELPS plancha stove in Guatemala, the PROLENA EcoStove in Nicaragua, the Trees, Water and People Justa stove in Honduras, the ProBec stoves in South Africa, the new generation of GTZ cooking stoves in Africa, and the famous Rocket stove are all designed using his principles. Winiarski's design approach combines both clean burning and optimized heat transfer characteristics. Any type of intermittently fed wood burning stove can first be designed by locals to meet their needs and then finished by adapting these principles.

Batch fed and fan assisted stoves operate differently. These alternative stove design methods can be used as successfully to improve wood burning stoves. While many experts are working on these two approaches, both Crispin Pemberton-Pigott and Dr. Tom Reed have developed excellent working models, both of which are for sale. For more information on the Vesto stove please contact: Crispin Pemberton-Pigott at [vesto@newdawn.sz](mailto:vesto@newdawn.sz) or VESTO, P.O. Box 85274 Emmarentia, Republic of South Africa 2029. Dr. Tom Reed has spent decades experimenting with wood burning. His fan-assisted stoves are wonderful inventions. He currently markets them under the name "Wood Gas Camp Stoves." Dr. Reed can be reached through the Biomass Energy Foundation Press or at [tombreed@comcast.net](mailto:tombreed@comcast.net).

### PRINCIPLE ONE:

**Whenever possible, insulate around the fire using lightweight, heat-resistant materials.** If possible, do not use heavy materials like sand and clay; insulation should be light and full of small pockets of air. Natural examples of insulation include pumice rock, vermiculite, perlite, and wood ash. Lightweight refractory brick (brick that has been fired and is resistant to cracking at high temperatures) can be made from locally available sources (for recipes see Chapter 4, *Option #2: Insulative Ceramics*, page 27).

Insulation around the fire keeps it hot, which helps to reduce smoke and harmful emissions. Also, insulation around the fire keeps the heat from going into the stove body instead of into the pot.

Unfortunately, metal does not last very long near a hot fire. However, locally made ceramic tiles can be found that are durable when used as walls for a combustion chamber. Loose insulation can surround this type of construction. (See Chapter 4, *Option #1: Floor Tiles*, page 26.)

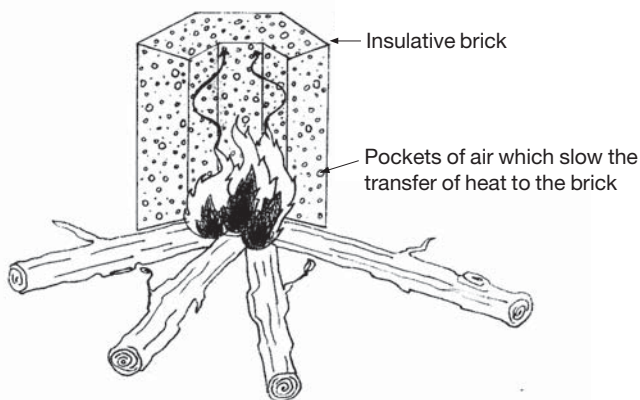

**Figure 7** - Insulation around the fire

**PRINCIPLE TWO:**

**Place an insulated short chimney right above the fire.** The combustion chamber chimney should be about three times taller than its diameter. Placing a short chimney above the fire increases draft and helps the fire burn hot and fierce. Smoke will contact flame in the chimney and combust, reducing emissions. Pots or surfaces to be heated are placed above the short chimney. A taller combustion chamber chimney, more than three times the width, will clean up more smoke, but a shorter chimney will bring hotter gases to the pot. The very tall combustion chamber chimney can develop too much draft bringing in too much cold air that will decrease heat transfer.

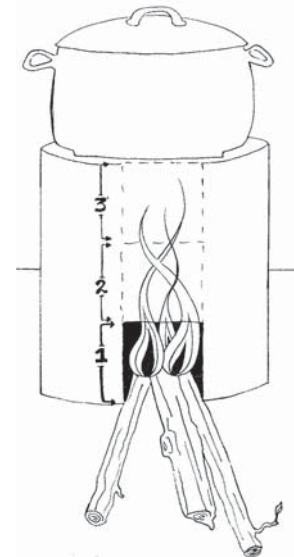

**Figure 8** - An insulated short chimney above the fire

**PRINCIPLE THREE:**

**Heat and burn the tips of the sticks as they enter the fire.** If only the wood that is burning is hot there will be much less smoke. Try to keep the rest of the stick cold enough that it does not smolder and make smoke. The goal is to make the proper amount of gas so that it can be cleanly burned without making charcoal or smoke. Smoke is un-burnt gas! It is harmful to breathe. Even cleaner looking combustion contains harmful emissions.

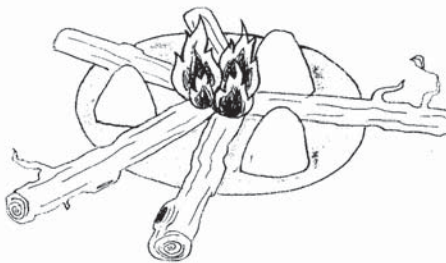

**Figure 9** - Cleaner Burning

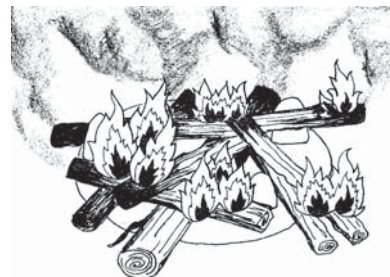

**Figure 10** - Smoldering Wood Makes Smoke

**PRINCIPLE FOUR:**

**High and low heat are created by how many sticks are pushed into the fire.** Adjust the amount of gas made and fire created to suit the cooking task. (Wood gets hot and releases gas. The gas catches fire and makes heat.)

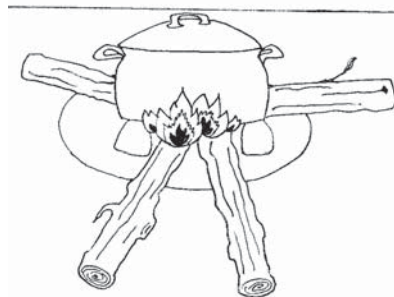

**Figure 11** - Low Heat

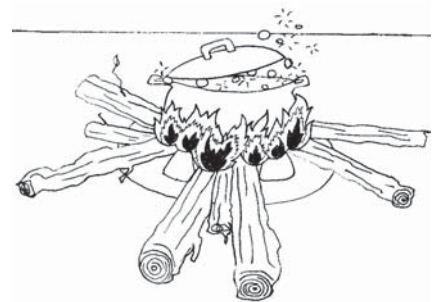
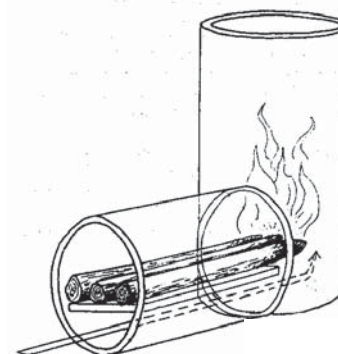

**Figure 12** - High Heat



**PRINCIPLE FIVE:**

**Maintain a good fast draft through the burning fuel.** Just as blowing on a fire and charcoal can make it hotter, having the proper amount of draft will help to keep high temperatures in your stove. A hot fire is a clean fire.



**Figure 13 - Maintaining a Good Draft**

**PRINCIPLE SIX:**

**Too little draft being pulled into the fire will result in smoke and excess charcoal.** But too much air just cools the fire and is not helpful. Smaller openings into the fire help to reduce excess air. Improving heat transfer to the pot or griddle is the most important factor that will reduce fuel use in a cooking stove. Improving combustion efficiency reduces pollution but is less important when trying to save firewood.

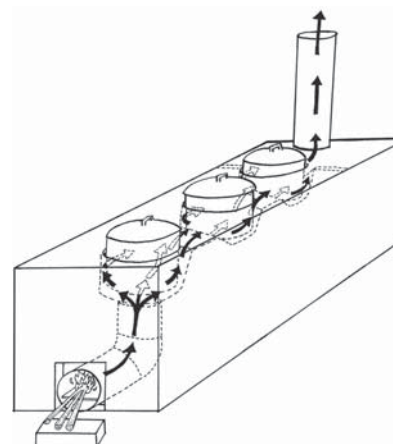

**Figure 14 - Balancing the air flow in a multipot stove**

**PRINCIPLE SEVEN:**

**The opening into the fire, the size of the spaces within the stove through which hot air flows, and the chimney should all be about the same size.** This is called **maintaining constant cross sectional area**, and helps to keep good draft throughout the stove. Good draft not only keeps the fire hot; it is also essential so that the hot air created by the fire can effectively transfer its heat into the pot. Air does not carry very much energy, so a lot of it needs to go through the stove in order to accomplish the task of heating food or water.

The size of the openings is larger in more powerful stoves that burn more wood and make more heat. **As a general rule, a door into the fire with a square opening of twelve centimeters per side and equally sized chimney and tunnels in the stove will result in a fire suited to family cooking.** Commercial stoves need bigger openings, tunnels, and chimneys because bigger fires require more air. For more information, please see the chapter *Designing Stoves with Baldwin and Winiarski* on page 17.

**Figure 15 - Maintaining Constant Cross-Sectional Area**

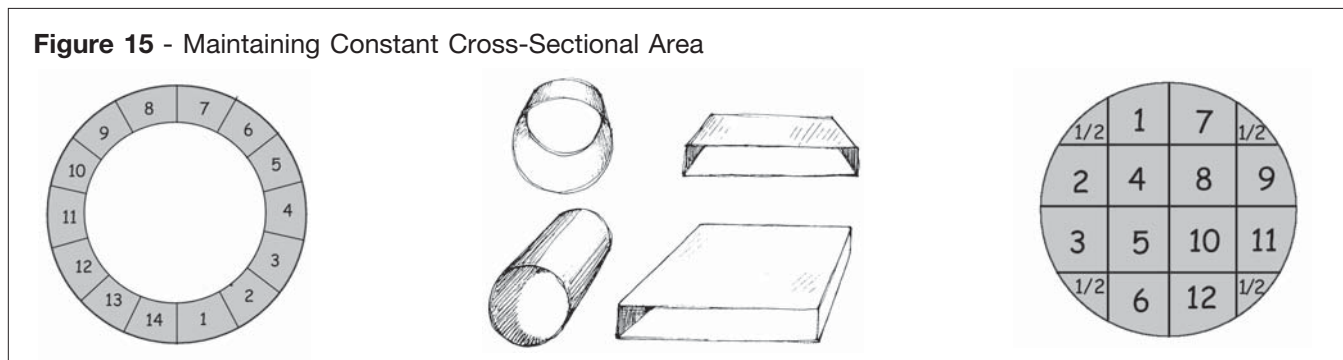

## PRINCIPLE EIGHT:

**Use a grate under the fire.** Do not put the sticks on the floor of the combustion chamber. Air needs to pass under the burning sticks, up through the charcoal, and into the fire. A shelf in the stove opening also lifts up sticks so air can pass underneath them. When burning sticks, it is best to have them close together and flat on the shelf, with an air space in between each stick. The burning sticks keep the fire hot, each fire reinforcing the other to burn more completely. It is optimum if the air passes under the shelf and through the coals so that when it reaches the fire it is preheated to help the gases reach complete combustion. Air that passes above the sticks is not as helpful because it is colder and cools the fire. A hot raging fire is clean, but a cold fire can be very dirty.

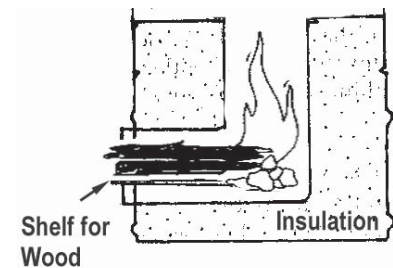

Figure 16 - Use of a Grate Under the Fire

## PRINCIPLE NINE:

**Insulate the heat flow path.** Cooks tend to like stoves that boil water quickly. This can be especially important in the morning when family members need to get to work. If heat goes into the body of the stove, the pot boils less quickly. Why heat up fifty or one hundred kilograms of stove each morning when the desired result is to heat up a

kilogram of food or a liter of water? Using insulative materials in the stove keeps the flue gases hot so that they can more effectively heat the pan or griddle. Insulation is full of air holes and is very light. Clay and sand or other dense materials are not insulation. Dense materials soak up heat and divert it from cooking food.

## PRINCIPLE TEN:

**Maximize heat transfer to the pot with properly sized gaps.** Getting heat into pots or griddles is best done with small channels. The hot flue gases from the fire are forced through these narrow channels, or gaps, where it is forced to scrape against the pot or griddle. If the gap is too large the hot flue gases mostly stay in the middle of the channel and do not pass their heat to the desired cooking surface. If the gaps are too small, the draft diminishes, causing the fire to be cooler, the emissions to go up, and less heat to enter the pot.

When designing a stove, it is possible to decrease the gap in the channel next to the pot or griddle until the fire becomes “lazy.” Using trial and error, open up the gap little by little until the fire stays hot and vigorous.

The two most important factors for getting large amounts of heat into a pot or griddle are: 1) keep the flue gases that touch the pot or griddle as hot as possible; and, 2) force the hot gases to scrape against the surface quickly, not slowly. Air does not hold much heat. Faster hot flue gases scraping against the pot or griddle will transfer much more heat than slow-moving cooler air.

The size of the channel can be estimated by keeping the cross sectional area constant throughout the stove. When using an external chimney that provides greater draft, channel gaps can be reduced. For more information on gaps, please see the next chapter.

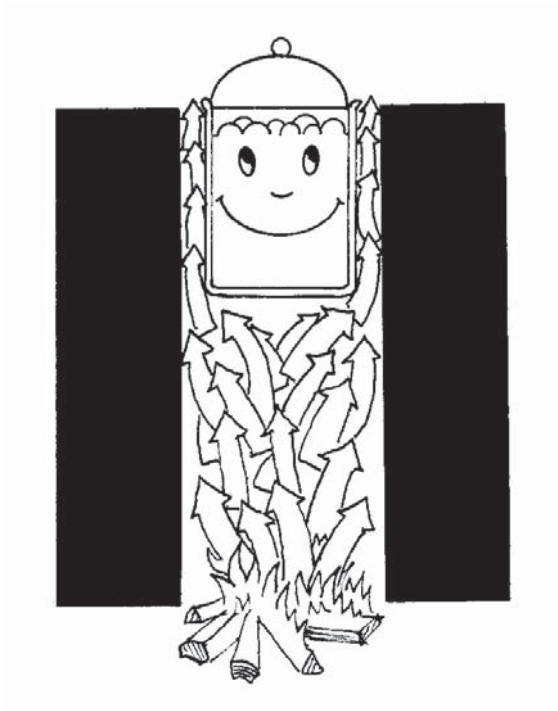

**Figure 17** - A proper sized gap optimizes heat transfer to the pot

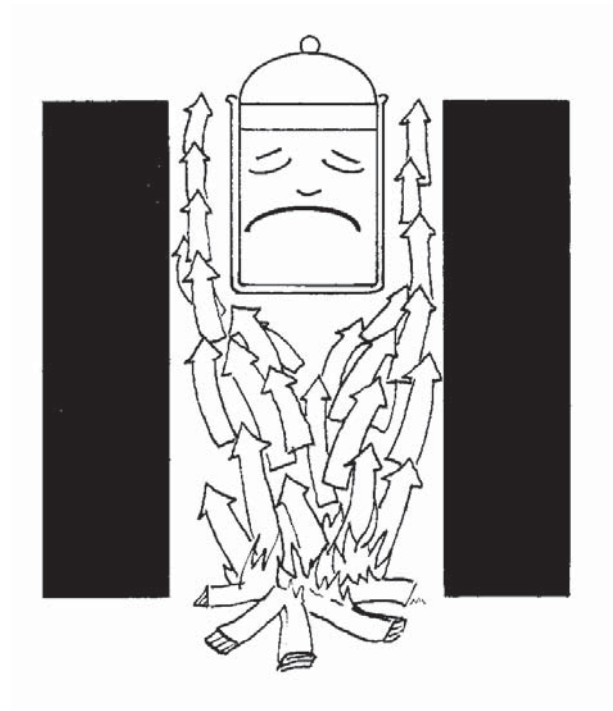

**Figure 18** - Too large a gap will reduce heat transfer to the pot

## Chapter 3

# Designing Stoves with Baldwin & Winiarski

Forcing hot flue gases to flow past the surface area of a pot or griddle in a narrow channel is a stove design strategy popularized by both Dr. Samuel Baldwin and Dr. Larry Winiarski. In 1982 Dr. Winiarski created the pot skirt, a cylinder of sheet metal that surrounded the pot, which formed a narrow channel increasing heat transfer efficiency. Dr. Baldwin studied stoves in Africa and in 1987 wrote his seminal book *Biomass Stoves: Engineering Design, Development, and Dissemination* in which he also stresses the importance of using narrow channels to deliver more heat to the pot.

In general, there are three ways to increase convective heat transfer:

- ▶ The flue gases scraping the surface to be heated, should be as hot as possible.
- ▶ The surface area of the heat exchanger should be as large as possible.
- ▶ The velocity of the hot flue gases should be increased as much as possible. A faster flow over the exterior of the pot disturbs the stagnant boundary layer of air that slows effective heating.

The narrow channels formed close to the pot by an insulated skirt (see Figure 19) can help to optimize the three principles simply and inexpensively. Although narrowing the gap increases heat transfer efficiency, doing so also decreases the flow of air through the stove. The size of the gap must therefore be in relation to the firepower. As more wood is burned per minute, more air is needed to

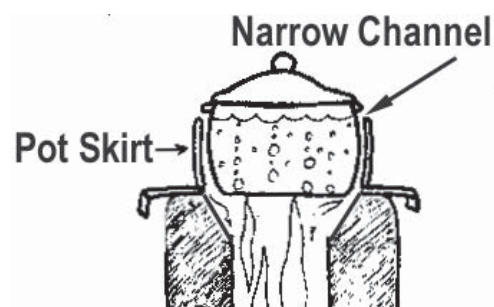
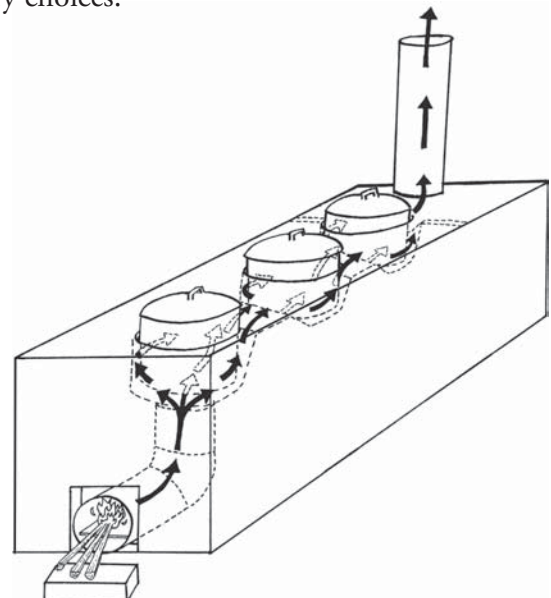

**Figure 19** - The narrow channel close to the pot increases convective heat transfer

support both the combustion and the necessary flow to avoid back drafting into the room. If too small a gap is used the fire may burn well while simmering but will be short of air when operated at high power. On the other hand, very large channel gaps will sustain a large fire but unnecessary amounts of heat will be lost due to poor heat transfer.

## Design Strategies

The two stove designers approach the problem of sizing the channel gap differently. Winiarski in *Rocket Stove Design Principles* (1997), advises technicians to start designing stoves by maintaining constant cross sectional area throughout the stove. He sets the cross sectional area at the opening into the fire, or fuel magazine, and then creates appropriate gaps around the pots based on maintaining the same cross sectional area. Baldwin's method requires a designer to pick a maximum high power for the stove design. Starting from a fixed firepower the size of the channel gap is then determined. In one case, Winiarski chooses the size of the fuel magazine first while Baldwin uses firepower as the starting point. The spaces within the stove are determined by either of these two primary choices.



**Figure 20** - Hot flue gases are forced to flow past the surface of the pots in a narrow channel

## Winiarski Method

The following stove diagram and tables (see pages 19-20) show how the size of the channels near to the pot or griddle change as the opening into the fire is expanded. Dr. Winiarski suggests that a 12 cm by 12 cm opening is usually sufficient for a family sized cooking stove. Larger openings that allow more wood into the fire result in higher power and larger channel gaps.

Establishing the same cross sectional area everywhere in a cooking stove ensures sufficient draft for good combustion while resulting in

channel gaps that increase heat transfer efficiency. This means that the opening into the combustion chamber, the combustion chamber, the air gap under the pot or griddle, and the chimney are the same size (equal number of square centimeters) while having different shapes. Winiarski advises designers to create prototype cooking stoves that maintain the cross sectional area to keep the draft flowing at an optimal rate. Slowing down the draft hurts both combustion and heat transfer efficiency to the pot.

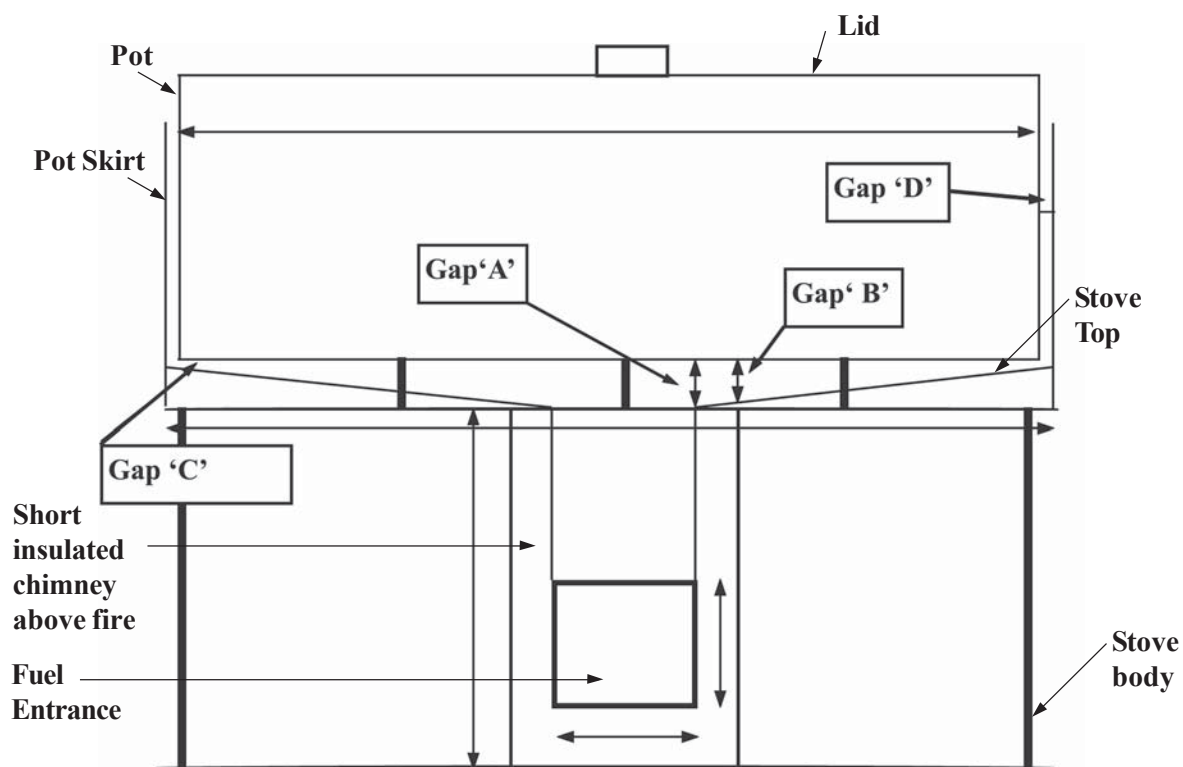

**Figure 21** - A Typical Winiarski Stove  
*(Use this diagram along with the calculations found on pages 19-25 to determine proper gap size)*



## CROSS SECTIONAL AREA FOR SQUARE COMBUSTION CHAMBERS

Use these tables to create stoves with constant cross sectional area

**Table 1**

<b>12 cm X 12 cm Square Combustion Chamber</b>				
<b>Pot Size (cm)</b>	<b>20</b>	<b>30</b>	<b>40</b>	<b>50</b>
GAP A (cm)	3	3	3	3
GAP B (cm)	2.5	2.5	2.5	2.5
GAP C (cm)	2.3	1.5	1.1	0.9
GAP D (cm)	2.1	1.5	1.1	0.9
<b>14 cm X 14 cm Square Combustion Chamber</b>				
<b>Pot Size (cm)</b>	<b>20</b>	<b>30</b>	<b>40</b>	<b>50</b>
GAP A (cm)	3.5	3.5	3.5	3.5
GAP B (cm)	3.1	3.1	3.1	3.1
GAP C (cm)	3.1	2.1	1.6	1.2
GAP D (cm)	2.7	2	1.5	1.2
<b>16 cm X 16 cm Square Combustion Chamber</b>				
<b>Pot Size (cm)</b>	<b>20</b>	<b>30</b>	<b>40</b>	<b>50</b>
GAP A (cm)	NA	4	4	4
GAP B (cm)	NA	3.7	3.7	3.7
GAP C (cm)	NA	2.7	2	1.6
GAP D (cm)	NA	2.5	1.9	1.6
<b>18 cm X 18 cm Square Combustion Chamber</b>				
<b>Pot Size (cm)</b>	<b>20</b>	<b>30</b>	<b>40</b>	<b>50</b>
GAP A (cm)	NA	4.5	4.5	4.5
GAP B (cm)	NA	4.3	4.3	4.3
GAP C (cm)	NA	3.4	2.6	2.1
GAP D (cm)	NA	3.1	2.4	2
<b>20 cm X 20 cm Square Combustion Chamber</b>				
<b>Pot Size (cm)</b>	<b>20</b>	<b>30</b>	<b>40</b>	<b>50</b>
GAP A (cm)	NA	5	5	5
GAP B (cm)	NA	4.9	4.9	4.9
GAP C (cm)	NA	4.2	3.2	2.5
GAP D (cm)	NA	3.7	3	2.4

**CROSS SECTIONAL AREA FOR CIRCULAR COMBUSTION CHAMBERS****Table 2**

<b>12 cm Diameter Circular Combustion Chamber</b>				
<b>Pot Size (cm)</b>	<b>20</b>	<b>30</b>	<b>40</b>	<b>50</b>
GAP A (cm)	3	3	3	3
GAP B (cm)	2	2	2	2
GAP C (cm)	1.8	1.2	0.9	0.7
GAP D (cm)	1.6	1.2	0.9	0.7
<b>14 cm Diameter Circular Combustion Chamber</b>				
<b>Pot Size (cm)</b>	<b>20</b>	<b>30</b>	<b>40</b>	<b>50</b>
GAP A (cm)	3.5	3.5	3.5	3.5
GAP B (cm)	2.4	2.4	2.4	2.4
GAP C (cm)	2.4	1.6	1.2	0.9
GAP D (cm)	2.2	1.5	1.2	0.9
<b>16 cm Diameter Circular Combustion Chamber</b>				
<b>Pot Size (cm)</b>	<b>20</b>	<b>30</b>	<b>40</b>	<b>50</b>
GAP A (cm)	NA	4	4	4
GAP B (cm)	NA	2.9	2.9	2.9
GAP C (cm)	NA	2.1	1.6	1.3
GAP D (cm)	NA	2	1.5	1.3
<b>18 cm Diameter Circular Combustion Chamber</b>				
<b>Pot Size (cm)</b>	<b>20</b>	<b>30</b>	<b>40</b>	<b>50</b>
GAP A (cm)	NA	4.5	4.5	4.5
GAP B (cm)	NA	3.4	3.4	3.4
GAP C (cm)	NA	2.7	2	1.6
GAP D (cm)	NA	2.5	1.9	1.6
<b>20 cm Diameter Circular Combustion Chamber</b>				
<b>Pot Size (cm)</b>	<b>20</b>	<b>30</b>	<b>40</b>	<b>50</b>
GAP A (cm)	NA	5	5	5
GAP B (cm)	NA	3.8	3.8	3.8
GAP C (cm)	NA	3.3	2.5	2
GAP D (cm)	NA	3	2.4	1.9

## Baldwin: Firepower Determines Channel Size

As can be seen in the chart below, Baldwin and Winiarski's methods seem to create similar sized gaps. These values are derived from charts found in *Biomass Stoves* which summarize Baldwin's findings. The chart is an approximation meant to serve as a guide to the relationship between firepower, wood use per hour, length and width of gap size, and stove efficiency.

**Table 3 - Baldwin's Suggested Gap Sizes**

Wood burned per hour (kg)	Skirt gap (mm)	Length of gap (cm)	Thermal efficiency of stove (%)	Firepower (kW)
0.50	8	20	40	2.8
0.75	10	20	35	4.1
1.00	11	20	30	5.5
1.25	12	20	28	6.9
1.50	13	20	26	8.3
1.75	14	20	25	9.6

A typical Winiarski designed stove with a square, 12 cm x 12 cm combustion chamber burns wood at approximately the rate of 1.5 kg/hr at high power. In his computer program Baldwin uses a 30 cm diameter pot as "family sized." Given this size of pot, the gap at the perimeter using the Winiarski model would be calculated by dividing the area ( $A = 12 \text{ cm} \times 12 \text{ cm} = 144 \text{ square cm}$  for a square combustion chamber) by the perimeter at the edge of the pot ( $P = \pi (d)$ , the circumference, or  $3.14 \times 30 = 94 \text{ cm}$ ). The resulting gap is  $144 \text{ cm}/94 \text{ cm} = 1.5 \text{ cm}$  (15 mm). Following Baldwin's chart, we see that a stove burning wood at a rate of 1.5 kg/hr. would call for a gap of 13 mm for maximum efficiency, a difference of 2 mm from Winiarski's model.

## Calculations

To use Winiarski's method of maintaining a constant cross sectional area under the pot, you will need to calculate the correct height of the gap under the pot. This height will vary as you move from the center of the combustion chamber out to the edge of the pot. To do this, calculate the needed gap at the edge of the combustion chamber and at the edge of the pot. Although this sounds complicated it is relatively straight forward. There are 5 steps to make this calculation:

1. Determine the area of the combustion chamber, which will be continued throughout the stove. If the combustion chamber is cylindrical, the area is calculated using the formula

$$A_c = \pi \cdot r_c^2$$

where  $A_c$  is the area,  $\pi = 3.14$ , and  $r_c$  is the radius. The radius is one-half the diameter. If the combustion chamber is square or rectangular, the area is calculated as

$$A_c = l \cdot w$$

where  $l$  is the height and  $w$  is the width.

2. At the edge of the insulated chimney above the fire, the gasses turn and follow the bottom of the pot. To determine the needed gap at the edge of the combustion chamber, first determine the circumference of the area that the hot gasses will pass through. To do this measure from the center of the combustion chamber outlet to the farthest edge,  $r_c$ . In a circular combustion chamber this will be the radius. In a square or rectangular chamber this will be from the center to one of the corners. Determine the circumference associated with this distance. This is

$$C_c = 2 \cdot \pi \cdot r_c$$

3. Next, divide the cross sectional area,  $A_c$ , determined in Step 1 by the  $C_c$  determined in Step 2. This is

$$G_c = A/C_c$$

where  $G_c$  is the needed gap between the bottom of the pot and the top edge of the combustion chamber.

4. Now determine the optimal gap at the edge of the pot. Measure the circumference,  $C_p$ , of the pot. This is the distance all the way around the pot. The circumference can be measured two ways. The easiest is to take a piece of string, wrap it around the pot and measure the length of the string. Alternately, you can determine the circumference from the diameter,  $r_p$ .

$$C_p = 2 \cdot \pi \cdot r_p$$

5. As in Step 3, divide the cross sectional area,  $A_c$ , determined in Step 1 by the  $C_c$  determined in Step 4 to calculate the needed gap at the edge of the pot,  $G_p$ . This is

$$G_p = A/C_p$$

As noted above, the area under the pot will need to be slowly decreased moving from the edge of the combustion chamber to the edge of the pot. Careful readers will note that this thinning of the gap is not linear. However, using the constant area thumb rule as an approximation is the easiest way to handle this. Smoothly match the gap distance from the edge of the combustion chamber to the edge of the pot by hand in a linear fashion.

After creating the prototype with a constant cross sectional area, the cooking stove will need to be fine-tuned by reducing the channel gap while watching the fire at high power. Set the gap as small as possible while making sure that the draft is sufficient for clean combustion. It is good practice to remember that the stoves will often be operated at very high power; therefore, the careful designer does not tighten gaps below the maximum possible firepower. Widening the distance beyond the theoretical best gap also provides some degree of protection against clogging by products of incomplete combustion.

---

### Example 1

Consider the case of a stove with a cylindrical combustion chamber 12 cm in diameter with a 30 cm cooking pot.

The first step is to calculate the cross sectional area of the combustion chamber. This is

$$A_c = \pi \cdot 6^2 = \pi \cdot 36 = 113 \text{ cm}^2$$

Next calculate the gap needed at the edge of the combustion chamber. First we find the circumference of the area that the hot gasses will pass through. This is

$$C_c = 2 \cdot \pi \cdot 6 = \pi \cdot 12 = 37.7 \text{ cm}$$

From this you can find the needed gap at the edge of the combustion chamber as

$$G_c = 113/37.7 = 3.0 \text{ cm} \quad \leftarrow$$

If this space were only two centimeters high, the cross sectional area at Gap A would only be 75.4 cm<sup>2</sup>, reducing the draft and increasing the production of smoke. If the space at Gap A were 5 centimeters, the cross sectional area would be 188.5 cm<sup>2</sup>. This area is so large that even though flow rate is maintained, the velocity of hot gases is decreased and gases are not forced to scrape against the pot and so cannot effectively deliver their energy to it.

At the edge of the pot, the circumference that the hot gasses need to pass through is

$$C_p = 2 \cdot \pi \cdot 15 = \pi \cdot 30 = 94.4 \text{ cm}$$

The needed gap at the edge of the pot is

$$G_p = 113/94.4 = 1.2 \text{ cm} \quad \leftarrow$$

We need to remember that this is an approximation and that the gap will need to be field tuned at the highest power setting of the stove. In addition, we will need to smoothly thin the gap from 3.0 cm at the edge of the combustion chamber to 1.2 cm at the edge of the pot.



## Example 2

Often it is less expensive to build square or rectangular combustion chambers. Consider the case of a 12 cm x 10 cm rectangular combustion chamber with a 30 cm diameter cooking pot.

The first step is to calculate the cross sectional area of the combustion chamber. This is

$$A_c = 12 \cdot 10 = 120 \text{ cm}^2$$

Next we calculate the gap needed at the edge of the combustion chamber. First we find the circumference of the area that the hot gasses will pass through. The distance from the center of the combustion chamber to the corner is

$$r_c = \frac{1}{2} \sqrt{10^2 + 12^2} = \frac{1}{2} \sqrt{244} = 7.8 \text{ cm}$$

We know this looks complicated but remember in the field you will be using a tape measure not geometry. With this we can find the circumference of the area at that point. This is

$$C_c = 2 \cdot \pi \cdot 7.8 = \pi \cdot 15.6 = 48.0 \text{ cm}$$

From this we can find the needed gap at the edge of the combustion chamber

$$G_c = 113/48.0 = 2.4 \text{ cm} \quad \leftarrow$$

At the edge of the pot, the circumference that the hot gasses need to pass through is

$$C_p = 2 \cdot \pi \cdot 15 = \pi \cdot 30 = 94.4 \text{ cm}$$

The needed gap at the edge of the pot is

$$G_p = 113/94.4 = 1.2 \text{ cm} \quad \leftarrow$$

Again we need to remember that this is an approximation and that the gap will need to be field tuned at the highest power setting of the stove. In addition, we will need to smoothly thin the gap from 2.4 cm at the edge of the combustion chamber to 1.2 cm at the edge of the pot.

## Example 3

Another application of the constant area thumb rule is determining the gap needed between the pot and an insulated pot skirt. An insulated pot skirt is a band of metal insulated on the outside that goes around the cook pot, forcing the hot gases to run along the sides of the pot. Consider the cook stove with the 12 cm cylindrical combustion chamber and the 30 cm pot examined in Example 1.

To calculate the gap between the pot and the skirt along the side walls, or Gap D in the diagram on page 18, start with the area of the cooking chamber found in Example 1.

$$A_c = \pi \cdot 6^2 = \pi \cdot 36 = 113 \text{ cm}^2$$

Divide this by the circumference around the pot.

$$C_p = 2 \cdot \pi \cdot 15 = \pi \cdot 30 = 94.4 \text{ cm}$$

The gap needed becomes

$$G_{skirt} = A_c / C_p = 113 / 94.4 = 1.2 \text{ cm}$$

Note that this is the same gap as between the edge of the pot and stove surface. Also the careful reader will have noted that this is an approximation. But it is a very good approximation. Also remember that this is only a starting point and should be tuned at the high power setting in the field.

## Conclusions

Both Winiarski's and Baldwin's methods result in workable solutions that seem to be closely related. Creating small channels to increase heat transfer efficiency is a common strategy engineers use to optimize heat transfer. Applying the practice to cooking stoves has been shown to effectively improve fuel efficiency. Even an open fire is often 90% efficient at the work of turning wood into heat. But only a small proportion, from 10% to 40% of the released heat makes it into the pot. Improving combustion efficiency can have little appreciable effect on overall system efficiency; i.e., decreased fuel use. On the other hand, improving heat transfer efficiency to the pot can make a large difference, saving significant amounts of firewood.

Stoves have to use gaps that are large enough to support the airflow at high power. Much less firepower is required to simmer food. But the efficiency of heat transfer suffers because the channels are larger than needed at this reduced rate of flow. For this reason, without adjustable gaps, stoves tend to display better heat transfer efficiency at high power. A pot skirt with adjustable gaps solves this problem.

It is interesting that Baldwin was impressed by the improvements made possible by placing a short insulated chimney above the fire, which is the defining characteristic of Winiarski's Rocket stove. By reconfiguring the combustion chamber in this way Baldwin reports an increase in velocity of hot flue gases due to the height of the chimney, which results in clean burning and good fuel efficiency (Page 43, *Biomass Stoves*). In practice installing a short insulated chimney above the fire seems to help clean up combustion. Forcing the cleaner hot flue gasses to scrape against the pot or griddle in narrow spaces can increase heat transfer efficiency without significantly increasing harmful emissions.

## Chapter 4

# Options for Combustion Chambers\*

Multiple tests of the sand and clay Lorena stove, beginning in 1983, showed that placing materials with high thermal mass near the fire can have a negative effect on the responsiveness, fuel efficiency, and emissions of a cooking stove because they absorb the heat from the fire. Examples of high thermal mass materials are mud, sand, and clay. When stoves are built from high thermal mass materials, their efficiency (when tested in the laboratory) can be worse than that of the three-stone fire.

So what other materials can be used? Cleaner burning stoves can produce such high temperatures in the combustion chamber (where the fire burns) that metal, even stainless steel, can be destroyed. Cast iron combustion chambers, though longer lasting, are expensive.

While mud, sand, and clay are high in thermal mass, they do have certain benefits. They are locally available, cheap, easy to work with, and are often long lasting because they don't burn out under the intense heat produced by a fire. Creativity and good engineering allow a stove designer to use these materials advantageously without allowing their high thermal mass to degrade the quality of the stove.

Stove makers have been using ceramic parts for many years. The Thai Bucket Stove uses a ceramic combustion chamber. The Kenyan Jiko Stove also uses a ceramic liner to protect the sheet metal stove body. Books have been written describing how to make clay combustion chambers that will last for several years.\*\* A women's co-operative in Honduras called Nueva Esperanza makes long-lasting refractory ceramic stove parts from a mixture of clay, sand, horse manure, and tree gum. These combustion chambers are used in the Doña Justa and Eco Stoves now popular in Central America.

The benefit to using ceramic combustion chambers in these instances is their longevity. As we shall see in the example below, the key to minimizing the drawback of ceramic material, which is its high thermal mass, is to use the least amount possible without compromising its strength and by surrounding it with an insulative material.

## Option #1: Floor Tiles

Don O'Neal (HELPS International) and Dr. Winiarski located an alternative material in Guatemala, an inexpensive ceramic floor tile called a *baldosa*. The *baldosa* is about an inch thick and can be cut or molded into appropriate shapes to make a combustion chamber. Loose insulation fills in between the combustion chamber and the inside of the stove body. Wood ash, pumice rock, vermiculite, and perlite are all good natural heat resistant sources of loose insulation. The *baldosa* is inexpensive and has lasted four years in the insulated HELPS and Trees, Water and People stoves built in Central America.

Figure 22 - Ceramic Floor Tile

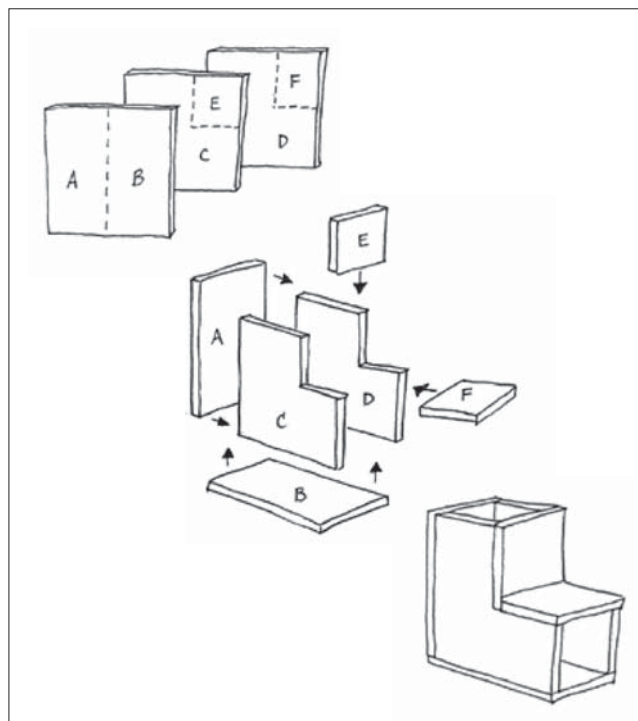

\* First published in *Boiling Point* #49

\*\*A good book on the subject is *The Kenya Ceramic Jiko: A Manual for Stovemakers* (Hugh Allen, 1991).

The *baldosa* floor tile is tested by placing it in a fire until it is red hot. Then the tile is removed and quickly dipped into a bucket of cold water. If the tile doesn't crack, it will probably last in the combustion chamber. *Baldosa* are usually made with red clay and are fired in a kiln at around 900° - 1000°C. They are somewhat porous and ring when struck with a knuckle. Using *baldosa* in a combustion chamber surrounded by loose insulation adds one more material option for the stove designer.

## Option #2: Insulative Ceramics

These recipes are intended to assist stove promoters in making insulative ceramics for use in improved wood burning cook stoves. Each of these materials incorporates clay, which acts as a binder. The clay forms a matrix around a filler, which provides insulation. The filler can be a lightweight fireproof material (such as pumice, perlite, or vermiculite), or an organic material (charcoal or sawdust). The organic material burns away, leaving insulative air spaces in the clay matrix. In all cases, the clay and filler are mixed with a predetermined amount of water and pressed into forms (molds) to create bricks. The damp bricks are allowed to dry, which may take several weeks, and then fired at temperatures commonly obtained in pottery or brick kilns in Central America.

Our test samples were made using low-fired “raku” clay obtained from a local potter's supply store. In

other countries, the best source of clay would be the kind used by local potters or brick makers. Almost everywhere, people have discovered clay mixes and firing techniques, which create sturdy ceramics. Insulative ceramics need to be lightweight (low density) to provide insulation and low thermal mass. At the same time, they need to be physically durable to resist breakage and abrasion due to wood being forced into the back of the stove. These two requirements are in opposition; adding more filler to the mix will make the brick lighter and more insulative, but will also make it weaker. Adding clay will usually increase strength but makes the brick heavier. We feel that a good compromise is achieved in a brick having a density between 0.8 gm/cc and 0.4 gm/cc.

The recipes in Table 4 indicate the proportions, by weight, of various materials. We recommend these recipes as a starting point for making insulative ceramics. Variations in locally available clays and fillers will probably require adjusting these proportions to obtain the most desirable results.

Insulative ceramics used in stoves undergo repeated heating and cooling (thermal cycling), which may eventually produce tiny cracks that cause the material to crumble or break. All of these recipes seem to hold up well to thermal cycling. The only true test, however, is to install them in a stove and use them for a long period of time under actual cooking conditions.

**Table 4 - Insulative Ceramics**

Type	Filler Wt. (Grams)	Clay (damp) Wt. (Grams)	Water Wt. (Grams)	Fired at (degrees C)	Density gr/cc
Sawdust	490	900	1300	1050	0.426
Charcoal	500	900	800	1050	0.671
Vermiculite	300	900	740	1050	0.732
Perlite Mix	807	900	1833	1050	0.612
Pumice Mix	1013	480	750	950	0.770

**Sawdust/Clay:**

In this formulation, fine sawdust was obtained by running coarse sawdust (from a construction site) through a #8 (2.36-mm) screen. Clay was added to the water and mixed by hand to form thick mud. Sawdust was then added, and the resulting material was pressed into rectangular molds. Excellent insulative ceramics can be made using sawdust or other fine organic materials such as ground coconut husks or horse manure. The problem with this method is obtaining large volumes of suitable material for a commercial operation. Crop residues can be very difficult to break down into particles small enough to use in brick making.

This method would be a good approach in locations where there are sawmills or woodworking shops that produce large amounts of waste sawdust.

**Charcoal/Clay:**

In this formulation, raw charcoal (not briquettes) was reduced to a fine powder using a hammer and grinder. The resulting powder was passed through a #8 screen. Clay was hand mixed into water and the charcoal was added last. A rather runny slurry was poured into molds and allowed to dry. It was necessary to wait several days before the material dried enough that the mold could be removed. Dried bricks were fired at 1050°C. Charcoal can be found virtually everywhere, and can be used when and where other filler materials are not available. Charcoal is much easier to reduce in size than other organic materials. Most of the charcoal will burn out of the matrix of the brick. Any charcoal that remains is both lightweight and insulative.

Charcoal/clay bricks tend to shrink more than other materials during both drying and firing. The final product seems to be lightweight and fairly durable, although full tests have not yet been run on this material.

**Vermiculite/Clay:**

In this formulation, commercial vermiculite (a soil additive), which can pass easily through a #8 (2.36 mm) screen, is mixed directly with water and clay and pressed into molds. Material is dried and fired at 1050°C.

Vermiculite is a lightweight, cheap, fireproof material produced from natural mineral deposits in many parts of the world. It can be made into strong, lightweight insulative ceramics with very little effort. The flat, plate-like structure of vermiculite particles makes them both strong and very resistant to heat.

Vermiculite appears to be one of the best possible choices for making insulative ceramics.

**Perlite Mix/Clay:**

For best results, perlite must be made into a graded mix before it can be combined with clay to form a brick. To prepare this mix, first separate the raw perlite into three component sizes: 3/8' to #4 (9.5 mm to 4.75 mm), #4 to #8 (4.75 mm to 2.36 mm), and #8 (2.36 mm and finer). Recombine (by volume) two parts of the largest size, one part of the midsize, and seven parts of the smallest size to form the perlite mix. This mix can now be combined with clay and water and formed into a brick, which is dried and fired.

Perlite is the mineral obsidian, which has been heated up until it expands and becomes light. It is used as a soil additive and insulating material. Perlite mineral deposits occur in many countries of the world, but the expanded product is only available in countries that have commercial “expanding” plants. Where it is available, it is both inexpensive and plentiful.

Perlite/clay bricks are some of the lightest usable ceramic materials we have produced so far.

**Pumice Mix/Clay:**

Pumice, like perlite, produces the best results when it is made into a graded mix. Care should be taken to obtain the lightest possible pumice for the mix. Naturally occurring volcanic sand, which is often found with pumice, may be quite heavy and unsuitable for use in insulative ceramics. It may be necessary to crush down larger pieces of pumice to obtain the necessary small sizes. The mix is prepared by separating pumice into three sizes: 0.5 inch to #4 (12.5 mm to 4.75 mm), #4 to #8 (4.75 mm to 2.36 mm), and #8 (2.36 mm) and smaller. In this case, the components are recombined (by volume) in the proportion of two parts of the largest size, one part of the midsize, and four parts of the smallest size. Clay is added to water and mixed to form thin mud. The pumice mix is then added and the material is pressed into molds. Considerable tamping or pressing may be necessary to work out the air and form a solid brick. The mold can be removed immediately and the brick allowed to dry for several days before firing.

Pumice is widely available in many parts of the world and is cheap and abundant. Close attention to quality control is required, and this could be a problem in many locations. It is very easy to turn a lightweight insulative brick into a heavy non-insulating one through inattention to detail. Pumice (and perlite as well) is sensitive to high heat (above 1100°C). Over-firing will cause the pumice particles to shrink and turn red, resulting in an inferior product. Despite these concerns, pumice provides a great opportunity to supply large numbers of very inexpensive insulative ceramics in many areas of the world.

There are many viable recipes to make lightweight refractory ceramic combustion chambers. Using insulation around the fire helps to boil water more quickly, makes the stove easier to light, and saves firewood. It is necessary to create very high temperatures in a combustion chamber in order to clean up dangerous emissions. Unfortunately these high temperatures quickly degrade metals, including stainless steel. Refractory insulative ceramics provide a material that is both long lasting and does not lower combustion temperatures as do materials with a higher thermal mass.



## Chapter 5

# In Field Water Boiling Test (WBT)

This test provides the stove designer with reliable information about the performance of wood burning stove models. The test consists of three phases that determine the stove's ability to:

- (1) bring water to a boil from a cold start;
- (2) bring water to a boil when the stove is hot; and,
- (3) maintain the water at simmering temperatures.

It is used to evaluate a series of stoves as they are being developed. The test cannot be used to compare stoves from different places because the different pots and wood used change the results.

The test is a simplified version of the University of California Berkeley (UCB)/Shell Foundation revision of the 1985 VITA International Standard Water Boiling Test. The wood used for boiling and simmering, and the time to boil are found by simple subtraction. All calculation can be done by hand in the field.

By using a standard pot, taking into account the moisture content of the wood, steam generated and other factors the complete UCB/Shell Foundation Water Boiling Test makes comparison of stoves from different places possible.

Before starting the tests...

1. **Collect at least 30 kg of air-dried fuel for each stove to be tested in order to ensure that there is enough fuel to complete three tests for each stove. Massive multi-pot stoves may require more fuel. Use equally dry wood that is the same size. Do not use green wood.**
2. Put 5 liters of water in the testing pot and bring it to a rolling boil. Make sure that the fire is very powerful, and that the water is furiously boiling! Use an accurate digital thermometer, accurate to 1/10 of a degree, to measure the local boiling temperature. Put the thermometer probe in the center of the testing pot, 5 cm above the pot bottom. **Record** the local boiling point on the data sheet (see page 34).

3. Do the tests in a place that is completely protected from the wind.
4. Record all results on the data sheet.

### Equipment used for the In Field Water Boiling Test:

- Scale of at least 6 kg capacity and 1 gram accuracy
- Heat resistant pad to protect scale
- Digital thermometer, accurate to 1/10 of a degree, with thermocouple probes that can be in liquids
- Timer
- Testing pot(s)
- Wood fixture for holding thermometer probe in water
- Small shovel/spatula to remove charcoal from stove
- Tongs for handling charcoal
- Dust pan for transferring charcoal
- Metal tray to hold charcoal for weighing
- Heat resistant gloves
- 3 bundles of air-dried fuel wood. One, used for simmering, weighs around 5 kgs. The other two bundles, used for cold and hot start boiling, weigh about 2 kgs each.

## Beginning of Test

- a. **Record** the air temperature.
  - b. **Record** weight of commonly used pot without lid. If more than one pot is used, record the weight of each pot. If the weights differ, be sure not to confuse the pots as the test proceeds. **Do not use pot lids** for this, or any other phase of the WBT.
  - c. **Record** weight of container for charcoal.
  - d. Prepare 2 bundles of fuel wood that weigh about 2 kgs each for the cold and hot start high power tests. Prepare 1 bundle of fuel wood that weighs about 5 kgs to be used in the simmering test. Use sticks of wood roughly the same size for all tests. **Record** approximate dimensions of the fuel wood. Weigh and **Record** weights in spaces marked # on the attached data sheet. Identify each bundle and keep them separate.
6. When the water in the first pot reaches the local boiling temperature as shown by the digital thermometer, rapidly do the following:
    - a. **Record** the time at which the water in the primary pot (Pot # 1) reaches the local boiling point of water. **Record** the water temperature for other pots as well.
    - b. Remove all wood from the stove and put out the flames. Knock all loose charcoal from the ends of the wood into the tray for weighing charcoal.
    - c. Weigh the unburned wood from the stove together with the remaining wood from the pre-weighed bundle. **Record** the result.
    - d. Weigh each pot, with its water. **Record** weight.
    - e. Remove all the charcoal from the stove, place it with the charcoal that was knocked off the sticks and weigh it. **Record** the weight of the charcoal and container.

### High Power (Cold Start) Phase:

The stove should be at room temperature.

1. Fill each pot with 5 L of clean water (~20°). **Record** the weight of pot(s) plus the water.
2. Using the wooden fixtures, place a thermometer probe in each pot so that water temperature may be measured in the center, 5 cm from the bottom. Make sure a digital thermometer is used. **Record** water temperatures.
3. **Record** the weight of the starting materials. Always use the same amount and material.
4. Start the fire using the wood from the first 2 kg bundle.
5. Once the fire has caught, start the timer and **Record** "0". If using a watch **Record** the starting time. Bring the first pot rapidly to a boil without being excessively wasteful of fuel.

This completes the high power (cold start) phase. Continue without pause to the high power (hot start) portion of the test. Do not allow the stove to cool.

### High Power (Hot Start) Phase

1. Refill the pot(s) with 5 L of fresh cold water. Weigh pot(s) (with water) and measure the initial water temperatures; **Record** both measurements.
2. Start the fire using kindling and wood from the second 2 kg bundle. **Record** weight of any additional starting materials.
3. **Record** the time when the fire starts and bring the first pot rapidly to a boil without being excessively wasteful of fuel.
4. **Record** the time at which the first pot reaches the local boiling point. **Record** the temperature of all pots.

5. After reaching the boiling temperature, rapidly do the following:
  - a. Remove all wood from the stove and knock off any loose charcoal into the charcoal container. Weigh the wood removed from the stove, together with the unused wood from the second bundle. **Record** the result.
  - b. Weigh each pot, with its water and **Record** these weights.
6. Remove all remaining charcoal from the stove and weigh it (including charcoal which was knocked off the sticks). **Record** the weight of the charcoal plus container.

**Without pause, proceed directly with the simmering test.**

### **Low Power (Simmering) Test**

This phase is designed to test the ability of the stove to simmer water using as little wood as possible. Use the 5 kg bundle of wood to bring the water to boil. Then record the weight of the remaining wood and simmer the water for an additional 45 minutes.

**Only the primary pot will be tested for simmering performance.**

Start of Low Power test:

1. **Record** the weight of the 5 kg bundle of fuel.
2. Refill the pot with 5 L of cold water. Weigh the pot (with water). **Record** weight. **Record** temperature.
3. Rekindle the fire using kindling and wood from the weighed bundle. **Record** the weight of any additional starting materials. Replace the pot on the stove and **Record** the start time when the fire starts.

4. Bring the pot rapidly to a boil without being excessively wasteful of fuel. As soon as local boiling temperature is reached, do the following steps **quickly and carefully**:
5. **Record** the boiling time and temperature. Quickly weigh the water in the primary pot and return it to the stove. **Record** the weight of the pot with water. **Record** the weight of remaining wood in 5 kg bundle. Replace the thermometer in the pot and continue with the simmer test by reducing the fire. **Keep the water as close to 3°C below the boiling point as possible.**
6. **Record** temperature of the water.
7. **Record** the time. For the next 45 minutes maintain the fire at a level that keeps the water temperature as close as possible to 3°C below the boiling point.
8. After 45 minutes rapidly do the following:
  - a. **Record** the finish time of the test (this should be 45 minutes).
  - b. **Record** the temperature of the water at end of test.
  - c. Remove all wood from the stove and knock any loose charcoal into the charcoal weighing pan. Weigh the remaining wood, including the unused wood from the preweighed bundle. **Record** the weight of wood.
  - d. Weigh the pot with the remaining water. **Record** the weight.
  - e. Extract all remaining charcoal from the stove and weigh it (including charcoal which was knocked off the sticks). **Record** the weight of pan plus charcoal.

This completes the full water boiling test. The full test should be done at least three times for each stove for accurate results.

**It is ok if temperatures vary up and down, but:**

- 1. The tester must try to keep the simmering water as close as possible to 3°C below the local boiling point.**
- 2. The test is invalid if the temperature in the pot drops more than 6°C below the boiling temperature.**
- 3. The tester should not further split the fuel wood into smaller pieces to try to reduce power.**

## **ANALYSIS of RESULTS:**

- Figure out the time to boil for cold start, hot start, and for the boiling phase of the simmer test.
- Calculate the wood use by subtracting the wood left at the end of each phase from the starting weight. Do this for cold start high power, hot start high power, boiling phase of the simmer test, and simmering.
- Calculate the water lost to steam for each of the four phases by subtracting the remaining weight from the starting weight of the water.
- Do the same for the charcoal produced.
- Use these numbers to evaluate stove performance. Change the stove design to reduce wood use and to create less charcoal. Making a lot of charcoal indicates poor combustion.
- Calculating the steam lost is a valuable method to check that performance is similar in all phases. Usually the hot start high power phase uses substantially less fuel, and time to boil is faster compared to the cold start high power phase. If there are significant differences between the recorded weights for wood use, time to boil, and steam lost between phase 2 and 3 it is recommended to repeat the testing procedure being careful to feed the fire without as much variation.
- Steam lost during the simmering phase is also a good indicator of the stoves ability to perform well during low power use. It is difficult to design a stove that can boil water quickly and simmer well without using a lot of fuel. However, since the majority of cooking time often occurs at low power (simmering), the greatest fuel savings can be made with a stove that saves fuel during this time. Producing large amounts of steam while simmering is an indicator that the stove is having a difficult time transitioning from the high power needed to boil water quickly to the low power needed for simmering food efficiently. Try changing the design so that the stove easily maintains a low simmer while keeping cooks happy with rapid boiling.

Remember that results from this test cannot be used to compare stoves tested in other places. The complete UCB/Shell Foundation test should be used for those purposes.

For more information, visit Aprovecho's web site at [www.Aprovecho.net](http://www.Aprovecho.net) or contact us at:

**Aprovecho Research Center**  
80574 Hazelton Rd.  
Cottage Grove, OR 97424  
(541) 942-8198

# Data Sheet

DATE

TEST NUMBER

STOVE

notes: IN FIELD WBT DATA AND CALCULATION SHEET  
 All spaces should be filled in.  
 Results from TWO and THREE should be similar.  
 Better stoves use less wood and make less charcoal.  
 Rapid boiling is usually appreciated by cooks.

local boiling point

air temperature

wood dimensions

weight pot one

weight pot two

weight charcoal container

	BUNDLE 1 - 2kg		cold start hi power 2 - 2kg		hot start hi power 3 - 5kg		bring to boil		4 simmer 45 minutes		
time	begin	end	begin	end	begin	end	begin	end	begin	end	
weight wood	A <input type="text"/>	B <input type="text"/>	#G <input type="text"/>	H <input type="text"/>	C <input type="text"/>	D <input type="text"/>	E <input type="text"/>	F <input type="text"/>	#K <input type="text"/>	L <input type="text"/>	M <input type="text"/>
water temp pot one	<input type="text"/>	<input type="text"/>	<input type="text"/>	<input type="text"/>	<input type="text"/>	<input type="text"/>	<input type="text"/>	<input type="text"/>	<input type="text"/>	<input type="text"/>	<input type="text"/>
water temp pot two	<input type="text"/>	<input type="text"/>	<input type="text"/>	<input type="text"/>	<input type="text"/>	<input type="text"/>	<input type="text"/>	<input type="text"/>	<input type="text"/>	<input type="text"/>	<input type="text"/>
weight pot one plus water	N <input type="text"/>	O <input type="text"/>	<input type="text"/>	<input type="text"/>	P <input type="text"/>	Q <input type="text"/>	R <input type="text"/>	S <input type="text"/>	<input type="text"/>	<input type="text"/>	T <input type="text"/>
weight pot two plus water	<input type="text"/>	<input type="text"/>	<input type="text"/>	<input type="text"/>	<input type="text"/>	<input type="text"/>	<input type="text"/>	<input type="text"/>	<input type="text"/>	<input type="text"/>	<input type="text"/>
weight fire starter	<input type="text"/>	<input type="text"/>	<input type="text"/>	<input type="text"/>	<input type="text"/>	<input type="text"/>	<input type="text"/>	<input type="text"/>	<input type="text"/>	<input type="text"/>	<input type="text"/>
weight charcoal and container	<input type="text"/>	U <input type="text"/>	<input type="text"/>	<input type="text"/>	<input type="text"/>	<input type="text"/>	<input type="text"/>	<input type="text"/>	<input type="text"/>	<input type="text"/>	V <input type="text"/>
											W <input type="text"/>

# Calculation Sheet

## Time to Boil:

\_\_\_\_\_ = B – A = Time to boil for cold start hi power phase

\_\_\_\_\_ = D – C = Time to boil for hot start hi power phase

\_\_\_\_\_ = F – E = Time to boil for boiling phase of simmering

## Wood Use:

\_\_\_\_\_ = G – H = Wood use for cold start hi power phase

\_\_\_\_\_ = I – J = Wood use for hot start hi power phase

\_\_\_\_\_ = K – L = Wood use for boiling phase of simmering

\_\_\_\_\_ = L – M = Wood use for simmering phase

## Water Converted to Steam:

\_\_\_\_\_ = N – O = Water lost to steam for cold start hi power phase

\_\_\_\_\_ = P – Q = Water lost to steam for hot start hi power phase

\_\_\_\_\_ = R – S = Water lost to steam for boiling phase of simmering

\_\_\_\_\_ = S – T = Water lost to steam during simmering phase

## Charcoal Created:

\_\_\_\_\_ = U – Y = Charcoal made in cold start hi power phase

\_\_\_\_\_ = V – Y = Charcoal made in hot start hi power phase

\_\_\_\_\_ = W – V = Charcoal either made or consumed during the simmering phase.  
(If this number is positive, then additional charcoal was created during simmering, and if negative, then charcoal was consumed during the simmering phase.)





## Appendix

# Glossary of Terms

**Baldosa**—Inexpensive ceramic floor tile about one inch thick that can be cut or molded into appropriate shapes to make a combustion chamber.

**Boundary layer**—The very thin layer of slow moving air immediately adjacent to a pot surface; insulates the pot from hot flue gases and diminishes the amount of heat that enters the pot.

**Charcoal**—The black, porous material that contains mostly carbon that is produced by burning of wood or other biomass.

**Convection**—The heat transfer in a gas or liquid by movement of the air or water.

**Combustion chamber**—The region of the stove where the fuel is burned.

**Combustion efficiency**—The percentage of the fuel's heat energy that is released during combustion. Combustion efficiency refers to the amount of the energy from the biomass that is turned into heat energy.

**Draft**—The movement of air through a stove and up a chimney.

**Emissions**—The byproducts from the combustion process that are discharged into the air.

**Excess air**—The amount of air used in excess of the amount for complete combustion.

**Firepower**—The rate of fuel consumption, usually in kg-fuel per hour.

**Flue Gas**—The hot gases that flow from the combustion chamber and out the chimney (if a chimney is present).

**Fuel efficiency**—The percentage of the fuel's heat energy that is utilized to heat food or water.

**Grate**—A framework of bars or mesh used to hold fuel or food in a stove, furnace, or fireplace.

**Haybox**—A relatively airtight insulated enclosure that maintains the temperature of the pot enabling food to be cooked to completion after the pot is removed from the stove.

**Heat transfer efficiency**—The percentage of heat released from combustion that enters a pot.

**High mass stove**—A stove made of uninsulated earth, clay, cast iron, or other heavy material that requires significant energy to be warmed during stove operation.

**High power**—A mode of stove operation where the objective is to boil water as quickly as possible; the highest power at which a stove can operate.

**Low power**—A mode of stove operation where the objective is to simmer the water or food product; the lowest power at which a stove can operate and still maintain a flame and simmer food.

**Pot skirt**—A tube, usually made of sheet steel, that surrounds a pot creating a narrow space so that more of the heat in the flue gases enter the pot.

**Retained heat**—Heat energy that warms the enclosures around the fire that does not escape to the surroundings; can be used for space heating.

***Vermiculite***—A lightweight, cheap, fireproof material produced from natural mineral deposits in many parts of the world. Vermiculite can be made into strong, lightweight, insulative ceramics with very little effort. It is very strong and resistant to heat, and appears to be one of the best possible choices for making insulative ceramics.

***Water Boiling Test (WBT)***—A test used to measure the overall performance of a cookstove. There are several versions of the water boiling test. In general the test consists of three phases. These are: (1) bringing water to a boil from a cold start; (2) bringing water to a boil when the stove is hot; and, (3) maintaining the water at simmering temperatures.





Aprovecho Research Center  
Advanced Studies in Appropriate Technology



SHELL  
FOUNDATION



United States  
Environmental Protection  
Agency

Office of Air & Radiation  
(6609J)

EPA-402-K-05-004